

**FIM RACING HOMOLOGATION PROGRAMME FOR HELMETS
(FRHPhe)**

**HOMOLOGATION MANUAL - FRHPhe-01
GENERAL TERMS AND CONDITIONS**

2021

Contents

| | | |
|------|--|----|
| I. | GLOSSARY | 3 |
| II. | FOREWORD | 7 |
| III. | SCOPE | 8 |
| IV. | TERM | 9 |
| V. | TECHNICAL INFORMATION AND CRITERIA | 10 |
| V.1 | ELIGIBLE HELMETS..... | 10 |
| V.2 | TESTING PROCEDURES | 10 |
| VI. | CONTRACTUAL TERMS AND CONDITIONS | 20 |

I. GLOSSARY

A. General terms of the FIM Racing Homologation programme

| | |
|--|--|
| Applicant | Legal entity applying for the FRHP before the FIM. The applicant shall be the company that markets the helmet to its end-users through customary sales channels (wholesalers/retailers/direct sales) or sells and/or supplies the helmets. The Applicant may, and in many cases will, also be a helmet manufacturer. |
| Application Form (homologation or update) | Part of the Homologation Manual, to be completed by the Applicant while applying for the FRHP. |
| FMN | National Motorcycling Federation affiliated to the FIM. |
| FRHP | FIM Racing Homologation Programme which grants recognition to products of compliance with safety requirement required for competitions. |
| FRHPhe | FIM Racing Homologation Programme for Helmets. FRHP that grants recognition to helmets that meet the FIM helmets Standard. |
| FRHPhe-01 | Current version of the FIM Helmet Racing Homologation Programme |
| FRHPhe-02 | Next version of the FIM Helmet Programme, that will be applied for Circuit and Off-Road helmets. It will enter in force in 2022 and will be mandatory for all FIM Competitions (except Trial) from 2025. The technical requirements, different from FRHPhe-01, for this new standard will be announced by the end of 2021 and will include a modified oblique test, an hemispherical anvil for linear impact tests and a cheek pad quick removal test. |
| FIM Racing Homologation | Official confirmation issued by the FIM acknowledging that Products comply with the required technical safety and competition requirement and meet particular specifications related to performance. |
| FIM Product Standard | Set of testing methods and corresponding performance criteria on the basis of which a Product may be granted an FIM Racing Homologation. |
| Homologation Emblem | Emblem issued by the FIM that includes the Applicant logo, the FRHP logo, the category of Product and the Product Model . |
| Homologation Fee | Cost associated with the homologation of a Product by the FIM as set out in this Homologation Manual. |
| Homologation Label | Official label provided exclusively by the FIM to the Applicant once homologation has been granted. |

| | |
|-------------------------------------|--|
| Homologation Manual | Formal document setting out the technical information, criteria and general contractual terms and conditions applying to the Applicant upon submission of its Application Form. The Homologation Manual shall be duly filled in, signed and returned by the Applicant to the FIM. This is a precondition for the homologation to proceed. |
| Homologation Notice | Contractual document that grants the homologation to the Applicant for a specific Product and sets out the specific conditions applicable to the Applicant. |
| Homologation Refusal | Formal letter transmitted by the FIM to the Applicant in the event that homologation is not granted to an Applicant for a particular Product Model. |
| Intellectual Property Rights | All trademarks, trade and business names, patents, copyright (including copyright in a computer program), database rights, design rights, registered designs, utility models, semi-conductor topography rights, inventions, know-how, confidential information and all other intellectual property and rights of a similar or corresponding nature in any part of the world, whether or not registered or capable of registration, in respect of such rights which are registrable and all applications for registration of any of the foregoing rights. |
| Personal Data | Any information relating to an identified or identifiable natural person; an identifiable natural person is one who can be identified, directly or indirectly, in particular by reference to an identifier such as a name, an identification number, location data, an online identifier or to one or more factors specific to the physical, physiological, genetic, mental, economic, cultural or social identity of that natural person. |
| Product | Any sort of light panel (FRHP _{lp}), helmet (FRHP _{he}), barrier (FRHP _{ba}), and paints (FRHP _{pa}) submitted by the Applicant for the homologation. |
| Product Model | The Model of Product indicated in the Application Form. |
| Product Sample | Unit of the Product that must be submitted by the Applicant at its cost to the FIM or the Testing Laboratory. |
| Supplier | Any third party that provides parts or material to assemble or to manufacture the product submitted by the Applicant for the FHRP. |
| Testing Laboratory | Private, public or private/public entity that has received an assignment from the FIM to perform tests according to a certain Homologation Manual and for the FRHP. |
| Test Report | Document issued by the Testing Laboratory that contains the test results relatively to a specific Application Form. |

B. Terms applicable only for helmets

| | |
|-----------------------------------|--|
| BrIC | <p>The Brain Injury Criterion (BrIC) is a measure used to determine the risk of inducing traumatic brain injury arising from a sudden head rotation and is calculated so:</p> $BrIC = \sqrt{\left(\frac{\omega_x}{\omega_{xC}}\right)^2 + \left(\frac{\omega_y}{\omega_{yC}}\right)^2 + \left(\frac{\omega_z}{\omega_{zC}}\right)^2}$ <p>Where: ω_x, ω_y and ω_z are maximum angular rates on X-, Y-, and Z-axis respectively ω_{xC}, ω_{yC} and ω_{zC} are the critical angular velocities in their respective directions:</p> <ul style="list-style-type: none"> ○ $\omega_{xC} = 66.25$ [rad/s] ○ $\omega_{yC} = 56.45$ [rad/s] ○ $\omega_{zC} = 42.87$ [rad/s] |
| Combination of accessories | Helmet configuration obtained with one or more external helmet accessories (e.g. aerodynamic devices, ventilation appendices). |
| Comfort padding | Pieces of soft foam inside the helmet used to fit as good as possible the head of the rider |
| FIM Helmets standard | Set of testing methods and corresponding performance criteria on the basis of which Helmets may be granted a FIM Racing Homologation. |
| Headform | Test device used as a human head surrogate in the testing of protective helmets. It is a three dimensional approximation of the human head, excluding facial features and pinnae, which contains a housing for the measuring equipment (sensors) in its centre of gravity. |
| Helmet | Personal safety equipment intended to protect the head of motorcycles riders in case of an accident. It is composed of a rigid shell, a protective padding, and comfort padding. The helmet is kept in place with a retention system composed of a chin strap and a Double-D ring closing system. |
| Helmet Model | Helmet size or range of helmet sizes of a certain name/design/shape/material as indicated in the Application Form. |
| Helmet Sample | Particular unit of a Helmet Model, of a certain Size and with a certain Combination of accessories. |
| Helmet Size | Suggested head circumference (expressed in cm) that ideally fits the helmet inner diameter. |
| HIC | The head injury criterion (HIC) is a measure of the likelihood of head injury arising from an impact for linear accelerations. The HIC is derived from the measurements of an accelerometer |

| | |
|---------------------------|--|
| | <p>mounted at the centre of mass of a crash test dummy's head placed inside the helmet to be tested.</p> <p>It is defined as:</p> $HIC = \max_{t_1, t_2} \left\{ (t_2 - t_1) * \left[\frac{1}{t_2 - t_1} \int_{t_1}^{t_2} a(t) dt \right]^{2.5} \right\}$ <p>where t1 and t2 are the initial and final times (in seconds) chosen to maximize HIC, and acceleration a is measured in g's (standard gravity acceleration). The time duration, t2 – t1, is limited to a maximum value of 36 [ms], usually 15 [ms].</p> |
| Oblique test | <p>During this test an helmet is crashed against an anvil at 45[°] to measure, in fully repeatable conditions, the capacity of the helmet to absorb and damp rotational solicitations generated in impacts combining normal and tangential forces.</p> |
| PLA | <p>Peak Linear Acceleration is the maximum resultant linear acceleration value recorded during a crash test at the centre of gravity of the headform. It is expressed in [g] (standard gravity acceleration).</p> |
| PRA | <p>Peak Rotational Acceleration is the maximum resultant rotational acceleration value recorded during a crash test at the centre of gravity of the headform. It is expressed in [rad/s²].</p> |
| Protective padding | <p>Crushable inner part of the helmet used to absorb energy during an accident.</p> |
| Shell | <p>Hard outer part of the helmet used to spread the impact load and prevent helmet penetration.</p> |

II. FOREWORD

Until now, the FIM has referred solely to existing international standards for the approval of helmets for use in its competitions.

In order to take account of a more complete and demanding evaluation of performance, and give specific and exclusive recognition to helmets that meet more demanding criteria, the FIM Technical and Circuit Racing Commissions have now launched a pioneering and unique programme, the FIM Racing Homologation Programme for helmets (FRHPhe), which features the latest state of art methods of testing.

Under this programme, the FIM will grant helmets a homologation certificate and labels, which will be a mandatory prerequisite to be entitled to access FIM Circuit Racing competitions.

To obtain such homologation, the helmet will have to meet the high performance and quality standard set by the FIM, in addition to be approved according to selected international standards.

The helmet properties will be evaluated through a test protocol which aims to trigger the development of helmets offering an optimal protection for riders. An optimal protection is understood as providing a minimised risk of skull fracture and of the multiple forms of brain damage, as well as a measured and controlled mechanical performance of the protective padding and the shell.

The FIM test approach will first assess the helmet response to very high and medium-low severity linear impacts, randomly in 13 out of 22 pre-established locations distributed all over the helmet surface. This aims at evenly assessing the level of protection against skull fracture and at featuring the mechanical properties of the protective padding (or liner).

Innovatively, the FIM test procedure will then pioneer the assessment of the helmet response to medium severity oblique impacts, aiming at evaluating the level of protection against brain injuries generated by critical rotational accelerations. The oblique test constitutes the most novel and modern aspect of the methods of testing and reflects a very common scenario occurring in real world accidents, although never addressed in international standards so far.

In addition, a penetration test will be included in the protocol and used to check the shell resistance to impacts against sharp objects.

FIM Homologated helmets will be required in all Circuit Racing FIM World Championships and Prize events as of 2019. The homologation will allow the FIM to ensure a more complete and high-end protection for its riders and in particular to better track and control helmets used in FIM competitions. It will also tend to preserve the interests of the homologated helmets' manufacturers. The FIM is hopeful that the new testing protocol can evolve still further, while serving as an inspiration for and cascading to international standards for road use.

This document was prepared under the direction of the FIM International Technical Commission, in collaboration with the Laboratory of Impact of the University of Zaragoza and leading road helmet

manufacturers. The document provides the TECHNICAL INFORMATION AND CRITERIA and the TERMS AND CONDITIONS , for interested parties wishing to apply to the Programme.

This document may be subject to amendments as determined by the FIM.

III. SCOPE

Eligibility of the FIM racing homologated Model, Size and combination of accessories to be used as from 2019 at FIM World Championship, Cup & Prize events as listed in below

- FIM Grand Prix World Championship
- FIM Superbike World Championship
- FIM Supersport World Championship
- FIM Sidecar World Championship
- Red Bull FIM MotoGP Rookies Cup
- FIM Supersport 300 World Championship
- FIM CEV Repsol Moto3 Junior World Championship
- FIM MotoE World Cup
- FIM World Record Attempts
- FIM Drag Bike World Cup
- FIM Endurance World Championship
- FIM Endurance World Cup

For further information concerning the events at which FIM racing homologated helmets are mandatory, please refer to the specific Regulations yearly issued for each World Championship, Cup or Prize.

IV. TERM

The terms and conditions of this Homologation Manual shall enter into force from the submission of the Application Form or the signature of this Homologation Manual by the Applicant, whichever is the earlier; they shall remain in force either during the Term of the Homologation Notice if the FIM Racing Homologation is granted, or until the Application is withdrawn if the FIM Racing Homologation is rejected.

V. TECHNICAL INFORMATION AND CRITERIA

V.1 ELIGIBLE HELMETS

A helmet is eligible for homologation if it is certified compliant with at least one of the following standards:

- UNECE 22.05 or 22.06 Type P
- Snell M 2015 or M 2020R or M 2020D
- JIS T8133 2015 Type 2 Full face

Moreover, eligible helmets must meet the following requirements:

- a protective lower face cover must be present and must be not detachable or moveable;
- the shell needs to be constructed in one piece (example: without any seam);
- a retention system with a strap and the double D-ring closing system must be present.

V.2 TESTING PROCEDURES

The test procedures of the present document are mainly based on UNECE 22.05.

The FRHPhe homologates a range of Sizes (those wished by the Applicant) of a specific Helmet Model, if all the test results fulfil the conditions as defined hereinafter. Within one Size, the homologation is valid for one or more Combination(s) of accessories and not for others (see hereinafter).

Testing procedures described in this document imply the use of 10 Helmet Samples per Size and per Combination of accessories, distributed in the different test phases as follows:

- Samples #1, #2 and #3: Conditioning, Weight, Linear impact tests
- Samples #4 and #5: Conditioning, Weight, Oblique impact tests
- Sample #6: Conditioning, Weight, Penetration tests
- Sample #7: Storage
- Sample #8, #9 and #10: Conditioning, Weight, Extra tests if needed

A detailed description of the test phases is given hereinafter.

The helmets are homologated per Size and per declared Combination of accessories (e.g. aerodynamic devices). The Applicant shall declare all accessories that will be fitted to the helmet and how they

will be combined for use. As a general rule, all declared Combinations of the declared accessories will be tested within the same homologation. The same Combinations of accessories shall be used at the events as reported in III SCOPE.

The Applicant shall declare the cover paint and the comfort padding used.

The correspondence between the Helmet Size and the corresponding EN960:2006 headform to be used in the test shall be according to **Table 1**.

Helmets of Size 50 cm or smaller shall be tested with the headform “A”. Helmets of Size 62 cm or larger shall be tested with the headform “O”.

| | | Largest Size specified (cm) | | | | | | | | | | | | | |
|------------------------------|----|-----------------------------|----|----|----|----|----|----|----|----|----|----|----|----|--|
| | | 50 | 51 | 52 | 53 | 54 | 55 | 56 | 57 | 58 | 59 | 60 | 61 | 62 | |
| Smallest Size Specified (cm) | 50 | A | A | C | | | | | | | | | | | |
| | 51 | | C | C | C | | | | | | | | | | |
| | 52 | | | C | C | E | | | | | | | | | |
| | 53 | | | | E | E | E | | | | | | | | |
| | 54 | | | | | E | E | E | | | | | | | |
| | 55 | | | | | | E | E | J | | | | | | |
| | 56 | | | | | | | J | J | J | | | | | |
| | 57 | | | | | | | | J | J | J | | | | |
| | 58 | | | | | | | | | J | J | M | | | |
| | 59 | | | | | | | | | | J | M | M | | |
| | 60 | | | | | | | | | | | M | M | M | |
| | 61 | | | | | | | | | | | | M | O | |
| | 62 | | | | | | | | | | | | | O | |

Table 1: Correspondence between tested headforms and Helmet Sizes

A. Samples #1, #2 and #3: Linear impact tests

This set of tests is designed to measure the impact absorption capacity of helmets. While the tests on Sample #1 and #2 focus only on the assessment of the protection against skull fracture and the mechanical characterization of the liner, the test on Sample #3 assesses the level of protection against brain damage, using more recent biomechanical bases.

A total of 13 linear impact tests shall be performed according to UNECE 22.05 7.3 (impact-absorption tests) with the following inclusions or modifications:

1. Helmet conditioning and weight

After solvent conditioning (as defined in UNECE 22.05 7.2.1), the Samples shall be stored in an atmosphere with a temperature of $(25 \pm 5)^\circ\text{C}$ and a relative humidity of $(50 \pm 20)\%$ for a period of not less than 4h. No further conditioning is required prior to test. The weight of the helmet fitted with the corresponding Combination of accessories as it will be used in competition (such as ventilation

devices, aerodynamics devices, ear cups, etc.) and with standard paint shall be measured and recorded.

2. Headforms

A set of headforms defined as follows shall be used:

- the external dimensions shall be according to EN960:2006
- the resonance frequency shall be according to EN960:2006
- the mass shall be according to EN960:2006 (instrumentation included)
- the position of the centre of gravity shall be according to EN960:2006

The headform inertia matrix of reference for the homologation is according to Table 2 (principal directions only, with regards to the centre of gravity):

| Headform denomination | Circumference [mm] | Mass [Kg] | Ixx [Kg cm ²] (± 5%) | Iyy [Kg cm ²] (± 5%) | Izz [Kg cm ²] (± 5%) |
|-----------------------|--------------------|--------------|----------------------------------|----------------------------------|----------------------------------|
| A | 495* | 3.1 (± 0.10) | 142.2 | 166.6 | 95.0 |
| C | 515* | 3.6 (± 0.10) | 172.6 | 203.3 | 113.2 |
| E | 535* | 4.1 (± 0.12) | 202.9 | 238.6 | 141.3 |
| J | 575* | 4.7 (± 0.14) | 264.0 | 318.3 | 193.1 |
| M | 605* | 5.6 (± 0.16) | 337.4 | 402.7 | 252.7 |
| O | 625* | 6.1 (± 0.18) | 383.6 | 461.1 | 293.5 |

*Tolerances according to UN 960:2006

Table 2: Properties of the headforms

3. Positioning of the helmet

The headform shall be positioned inside the helmet according to the following instructions:

- Head Positioning Index (HPI): the headform shall be positioned inside the helmet respecting the HPI as declared by the Applicant; the HPI shall respect the requirements of annex 5 of UNECE 22.05;
- Chinstrap tension: the retention system shall be adjusted under the chin of the headform and tightened to a tension of 75 ± 5 [N] (over strap friction) with a deflection angle of $45 \pm 5^\circ$.

Before each impact, the helmet shall be re-positioned according to the HPI and the retention system re-tensioned.

4. Measuring assembly

Headforms shall be fitted with an assembly of instruments containing a set of 3 linear accelerometers and 3 angular rate sensors, located at their centre of gravity.

The assembly shall enable the measurement at the centre of gravity of the three components of the linear acceleration (a_x, a_y, a_z) and the angular rate ($\omega_x, \omega_y, \omega_z$) over time.

The 3 linear accelerometers shall be oriented in the three natural directions of the headform. The accelerometers shall be capable of withstanding a maximum acceleration of 2000 [g] without damage. The acceleration data shall be sampled at a frequency of 10000 Hz and filtered in accordance with the latest edition of ISO 6487 (CFC 1000).

The angular rate sensors shall have a measurement capacity of 8000 [deg/s], between 0 and 2000 [Hz]. The angular velocity data shall be sampled at a frequency of 10000 [Hz] and filtered in accordance with the latest edition of ISO 6487 (CFC 180).

5. Anvil

Only a flat steel anvil shall be used, with a circular impact face of diameter 130 ± 3 [mm].

6. Impact sites and speed

UNECE 22.05 POINTS

5 linear impact tests in points B, X, P, R and S (according to UNECE 22.05 7.3.4.2) shall be performed in this sequence on Sample #1 and Sample #3. Only one impact per site shall be performed.

"EXTRA" POINTS

3 impact tests shall be performed on Sample #2. The impact points shall be selected among the 12 points as listed below and depicted in Figure 1, respecting the indicated order. The selected impact points shall not be less than 120 [mm] apart.

BP, in the front-superior area, situated in the vertical longitudinal plane of symmetry of the helmet (0°) and at a midpoint between the point B and the point P.

BXL, in the left (315°) front-lateral area, situated in the vertical plane and at an angle of 20° measured from Z above the AA' plane.

BXR, in the right (45°) front-lateral area, situated in the vertical plane and at an angle of 20° measured from Z above the AA' plane.

BXPL, in the left (315°) front-lateral-superior area, situated in the vertical plane and at a midpoint between the point BX and the point P.

- BXPR, in the right (45°) front-lateral-superior area, situated in the vertical plane and at a midpoint between the point BX and the point P.
- XPL, in the left (270°) lateral-superior area, situated in the central transverse vertical plane and at a midpoint between the point X and the point P.
- XPR, in the right (90°) lateral-superior area, situated in the central transverse vertical plane and at a midpoint between the point X and the point P.
- RXL, in the left (225°) rear-lateral area, situated in the vertical plane and at an angle of 20° measured from Z above the AA' plane.
- RXR, in the right (135°) rear-lateral area, situated in the vertical plane and at an angle of 20° measured from Z above the AA' plane.
- RXPL, in the left (225°) rear-lateral-superior area, situated in the vertical plane and at a midpoint between the point RX and the point P.
- RXPR, in the right (135°) rear-lateral-superior area, situated in the vertical plane and at a midpoint between the point RX and the point P.
- RP, in the rear-superior area, situated in the vertical longitudinal plane of symmetry of the helmet (180°) and at a midpoint between the point R and the point P.

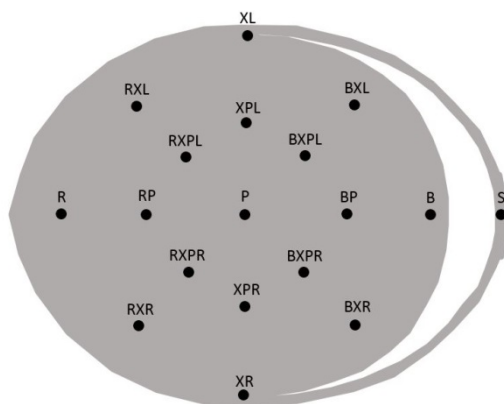

Figure 1: Identification of extra points

Impacts at points shall be within 10 [mm] radius of the defined point.

The test headform shall be positioned so that the designated point of the helmet is vertically above the centre of the anvil. The plane tangential to the point of impact shall be horizontal. This prescription does not apply for the S impact point. When testing impact point S, the impact point shall be not less than 15 [mm] from the rim.

The drop height shall be such to obtain an impact speed of:

- 8.20 (+0.15, -0.0) [m/s] for points B, X, P and R on Sample #1
- 6.00 (+0.15, -0.0) [m/s] for point S on Sample #1
- 8.20 (+0.15, -0.0) [m/s] for the "extra" points on Sample #2
- 5.00 (+0.15, -0.0) [m/s] for points B, X, P, R and S on Sample #3

The velocity of the moving mass shall be measured between 1 cm and 6 cm before impact, to an accuracy of 1%.

7. Acceptance criteria

The peak of the resultant linear acceleration (*PLA*) values (measured at the center of gravity of the headform) shall not exceed 275 [g] in all impact sites on Sample #1 and #2, 208 [g] on Sample #3.

The Head Injury Criterion (*HIC*) shall not exceed the value of 2880 in all impact sites on Sample #1 and #2, 1300 on Sample #3.

B. Samples #4 and #5: Oblique impact tests

The objective of this test is to measure, in fully repeatable conditions, the capacity of the helmet to absorb and damp rotational solicitations generated in impacts combining normal and tangential forces.

The test is based on a standard impact-absorption test, with a particular type of anvil and dropping speed. The test is conceived to be performed by using the same headforms of the linear impact test, instrumented with the same sensors.

A total of 5 oblique tests shall be performed similarly to linear impact tests of UNECE 22.05 7.3 (impact-absorption tests) with the following inclusions or modifications:

8. Helmet conditioning and weight

The same conditioning and weight measurement of the linear impact tests of the present procedure (Samples #1, #2 and #3) shall be applied.

9. Headforms

The oblique impact test shall use the same set of headforms as defined for the linear impact tests of the present procedure. An external additional coating is applied to the headform before the helmet is placed on the headform to be tested. The coating consists of a thin layer (<0.4 mm) of high performance platinum cure liquid silicone, with the technical data as indicated in Table 3 .

| Technical Data of the Coating | | |
|-------------------------------|-----------------------|----------------------|
| Mixed viscosity | 23 | [Pa*s] |
| Specific gravity | 1070 | [kg/m ³] |
| Specific volume | 9.32*10 ⁻⁴ | [m ³ /kg] |
| Shore A hardness | 10 | A |
| Tensile strength | 3.275 | [MPa] |
| 100% modulus | 0.1517 | [MPa] |
| Elongation at break % | 1000 | % |
| Die B tear strength | 17.863 | [kN/m] |
| Shrinkage | <0.1 | % |

Table 3: Properties of the additional coating

10. Positioning of the helmet

The headform shall be positioned inside the helmet in the same way as for the linear impact test of the present procedure.

11. Measuring assembly

The measuring assembly shall be the same as the one used for the linear impact tests of the present procedure.

12. Anvil

A so called "oblique anvil" shall be used. This type of anvil shall consist of a solid cylinder of diameter 130 ± 3 [mm] with an impact face consisting of a section at 45 ± 0.5 [°] with respect to its longitudinal axis, covered in abrasive paper. The abrasive paper shall be a sheet of grade 80 closed-coat aluminium oxide abrasive paper. The abrasive paper shall be replaced after significant damage (up to 3 tests).

13. Impact sites and speed

Impacts shall be performed in correspondence of the 5 sites as depicted in Table 4 and Table 5. Only one impact per site shall be performed. Helmet Sample #4 is used for front-lateral right (45°), rear (180°) and lateral left (270°), while Helmet Sample #5 is used for front (0°) and rear-lateral right (135°).

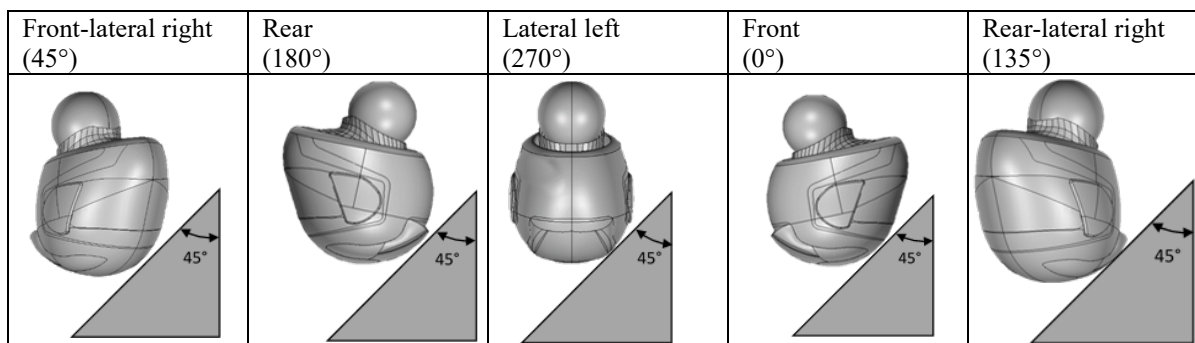

Table 4: Impact layouts for the oblique test: SIDE VIEW

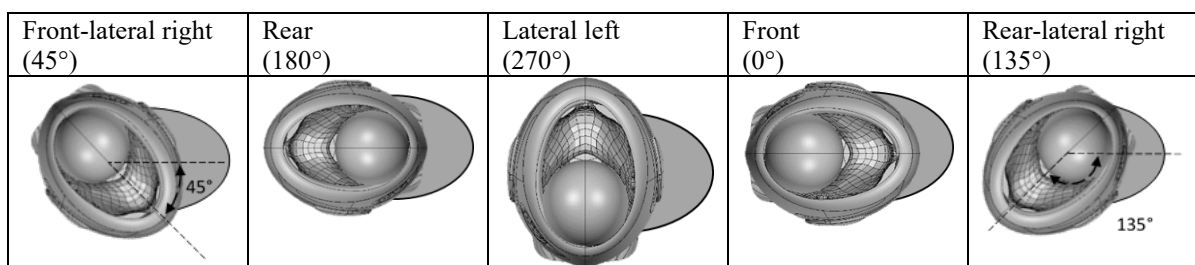

Table 5: Impact layouts for the oblique test: TOP VIEW

Impacts at points shall be within 10 [mm] radius of the defined point.

The test headform shall be positioned so that the designated point of the helmet is vertically above the centre of the anvil. For all oblique impact layouts, the central vertical axis of the headform shall be aligned to the vertical with a tolerance of ± 0.5 [°].

The drop height shall be such to obtain an impact speed of 8.00 (+0.15, -0.0) [m/s]. In a 45 [°] anvil, this speed gives the following normal (V_N) and tangential (V_T) components:

- $V_N = 5.66$ [m/s]
- $V_T = 5.66$ [m/s]

The velocity of the moving mass shall be measured between 1 [cm] and 6 [cm] before impact, to an accuracy of 1%.

14. Acceptance criteria

The peak of the resultant linear acceleration (*PLA*) values (measured at the center of gravity of the headform) shall not exceed 208 [g] in all impact sites on Sample #4 and #5.

The Head Injury Criterion (*HIC*) shall not exceed the value of 1300 in all impact sites on Sample #4 and #5.

The peak of the resultant rotational acceleration (*PRA*) shall be calculated differentiating the rotational velocity values. The *PRA* shall not exceed 10400 [rad/s²] in all impact sites on Sample #4 and #5.

The final time of the impact is calculated as the time where the resultant linear acceleration decreases at 5 [g] after its maximum peak.

The resultant value of *BrIC* must have at no time a value exceeding 0.78 during the defined impact time, in all impact sites of Sample #4 and #5.

C. Sample #6: Penetration test

The objective of these tests is to ensure the helmet shell integrity.

The testing procedure is in accordance with JIS T8133:2015 5.2 and 7.5 for a Type 2 protective helmet, with the following inclusions or modifications:

15. Helmet conditioning and weight

The same conditioning and weight measurement of the linear impact tests of the present procedure (Samples #1, #2 and #3) shall be applied.

16. Helmet support

The support for the helmet being subjected to the penetration test is spherical so as to provide reasonable support for the helmet and conformance with the interior of the helmet immediately beneath the site of the penetration test.

17. Penetration sites

The penetration test shall be conducted at a minimum of 2 points located at any site on the helmet on or above the "test line" as defined by Snell M2015. The two points shall be at least 75 [mm] apart from each other.

18. Acceptance criteria

There must be no contact between the striker tip and the spherical support surface in all the tests.

D. Sample #7: Storage

Sample #7 is the so called "reference helmet". The helmet is stored for reference.

E. Sample #8, #9 and #10: Extra tests

Sample #8, #9 and #10 shall be used for extra tests if needed.

F. Summary of acceptance criteria

A Helmet Model and Size is granted homologation (with the declared Combinations of accessories if any) if it complies with all the criteria in accordance with Table 6.

| FRHPhe-01 | |
|--------------------------|---|
| Samples #1 and #2 | - $PLA \leq 275$ [g] - $HIC \leq 2880$ |
| Sample #3 | - $PLA \leq 208$ [g] - $HIC \leq 1300$ |
| Samples #4 and #5 | - $PLA \leq 208$ [g] - $HIC \leq 1300$ - $PRA \leq 10400$ [rad/s ²] - $BrIC \leq 0.78$ |
| Sample #6 | No contact between striker tip and the support surface. |

Table 6: Acceptance criteria for FRHPhe-01

Notwithstanding the above, to be granted the homologation, the helmet shall not exhibit (after any of all the prescribed tests) any breakage or deformation that is deemed dangerous by the FIM.

IMPORTANT NOTICE

The present Technical information and criteria will be updated in the future (FRHPhe-02) . The mandatory use of helmet homologated according to the new standard is scheduled for 2025, but the technical details and thresholds are not defined yet and will be announced in advance on our website www.frhp.org.

G. Test Report

The test report should include all the information recorded as a result of the performance assessment of the helmet in accordance with Section **V.2 TESTING PROCEDURES**. Additionally, the test report should include at least the following information about the test:

- i. Photographs of the helmet as well as batch number and date of manufacture;
- ii. A complete listing of the Combination of accessories,
- iii. Any additional information requested at the discretion of the FIM.

H. FIM Marking and Labelling

Each helmet that has passed the requirements of this standard will have to be clearly labelled with FIM Label, which include an FIM hologram, to be firmly sewn on the helmet chinstrap. The FIM Label must be purchased from the FIM.

VI. CONTRACTUAL TERMS AND CONDITIONS

A. Application

In order to apply for the FIM Racing Homologation, the Applicant shall send the present Homologation Manual, duly completed and signed, with the requested information and attached documents (Application Form (homologation) to the FIM International Technical Commission (fhrp@fim.ch)). By doing so, the Applicant thereby confirms formal acceptance of the rules and procedures contained in the Homologation Manual, including the Technical Information and Criteria, the Terms and Conditions as well as the Application Form.

The Applicant shall apply for the FIM Racing Homologation for all specific Models of the Product which are intended for use in the related FIM events.

Only complete applications will be taken into consideration and it is the responsibility of each Applicant to ensure that all relevant information and documentation is provided. The FIM may request any further information it deems necessary. Applicants shall respond to any such request promptly and within the specified deadline if any.

Once the application is completed, the FIM will request that the Applicant send free of charge new and virgin Product Samples to, and only to, the following Testing Laboratory.

The Applicant shall not charge the FIM or the Testing Laboratory for the cost of the Product Samples.

Any duties, VAT or other taxes, levies, expenses or other charges payable in relation to the provision and delivery of Product to the FIM respectively the Testing Laboratory and/or the handling of such Products Samples (e.g. delivery cost, shipping cost, customs clearance costs, including the return of any Product Sample, if applicable) shall, irrespective of the place of delivery, be declared and paid by the Applicant at its own cost.

B. Data Protection

By applying to the FRHPhe and to access FIM homologation services and products, the Applicant authorizes FIM to collect, store, process, transfer and use its Personal Data in accordance with the EU General Data Protection Regulation and the Federal Act on Data Protection of Switzerland where FIM is incorporated. Unless the Applicant indicates otherwise, the consent the Applicant provides by applying to FRHPhe shall be considered express and valid indefinitely.

By applying to the FRHPhe the Applicant also authorizes FIM to transfer its Personal Data to any third parties (notably laboratories etc.) assisting in the management and implementation of the FIM homologation services, located in other countries with laws that may not guarantee the same level of data protection as Switzerland. The Applicant authorizes these third parties to use, retain and store its Personal Data for the purposes of the homologation services and products.

Further information concerning the privacy policy of the FIM Racing Homologation Program can be found on this website <https://www.frhp.org/>.

The Applicant is also entitled to request FIM to withdraw its consent, erase, rectify or obtain any personal data FIM holds about the Applicant by sending its written request to gdp-request@fim.ch.

In case the Applicant withdraws its consent or requests that its Personal Data be erased, FIM may be totally or partially unable to provide its homologation services or products.

C. Intellectual Property Rights

By applying to the FRHPhe, the Applicant acknowledges that the names of the FIM, the FIM Marks, the FIM Homologation Visuals, Emblem and Labels, the FIM logos, trademarks and/or trade names of or used by FIM (whether registered or unregistered or whether registrable or not) constitute an exclusive property of the FIM and/or that the FIM holds an exclusive title for their usage. The Applicant shall consequently under no circumstances make any use of such names of the FIM, the FIM Homologation Visuals, Emblem and Labels, the FIM logomarks, trademarks or trade names in a separate or combined manner either during the Homologation Notice or following its termination, contrary to the provisions of this Homologation Manual.

In addition, the use of the FIM Homologation Visuals, Emblem and Labels, the FIM logos by the Applicant shall under no circumstances give rise (directly or indirectly) to the mistaken impression on the part of the public and consumers (in particular) that the FIM might be considered as the manufacturer (or the manufacturer of any component part) of the Applicant's Product.

The Applicant agrees that he will not register, or cause to be registered, in any territory whatsoever, any name and/or denomination of any FIM Marks, Competitions and/or its classes or any logos, trademarks and/or trade names of the FIM or used by the FIM (whether registered or not or whether registrable or not) in connection with its activity, or any other trademark, trade name, word, logo or symbol that is identical or similar to any such name and/or denomination of any FIM Marks, the FIM Homologation Visuals, Emblem and Labels, the FIM logos, trademarks or trade names trademark and/or trade name (whether registered or not or whether registrable or not).

By applying to the FRHPhe, the Applicant represents and warrants that its application does not infringe the trademark and trade name rights of any third party. The Applicant is solely responsible for ensuring that this is the case.

The FIM may request evidence of a licence to use a third party's trademark and/or trade name. If the FIM considers that such a licence has not been validly obtained it may at its sole discretion refuse the application, or request that changes be made to the application.

The Applicant shall promptly inform FIM of any infringement of any intellectual property rights of the FIM that comes to the Applicant's attention.

The Applicant undertakes to provide, free of charge and royalty free, its trademark logo to be used by FIM in the FIM Homologation Emblem.

The Applicant shall indemnify and hold harmless the FIM from and against all claims, damage, losses, costs, (including, without limitation, all reasonable legal costs), expenses, demands or liabilities put forward by third parties for illegal competition, violation of copyright, claims of trademarks or industrial and intellectual property claims that may result from the activity of the Applicant not duly authorised by the FIM.

Regarding the FIM Homologation Emblem and Homologation Label, the FIM and the Applicant agree that:

- i. title to any and all rights in the FIM Homologation Emblem and Homologation Label shall vest in the FIM, save for rights in the Applicant trademark element of the FIM Homologation Emblem, which will remain the property of the Applicant absolutely;
- ii. all use of the FIM Homologation Emblem and Homologation Label by the FIM shall cease upon termination or expiry of this Homologation Manual or the Homologation Notice, unless the Applicant trademark element of the FIM Homologation Emblem is removed therefrom. The FIM shall be entitled to continue to use the remaining elements of the FIM Homologation Emblem after termination or expiry of this Homologation Manual;
- iii. all use of the FIM Homologation Emblem and Homologation Label by the Applicant shall cease upon termination or expiry of this Homologation Manual or the Homologation Notice; the Applicant shall be entitled to continue to use the Applicant trademark only after termination or expiry of this Homologation Manual;
- iv. The Applicant shall not bring any action in respect of the FIM Homologation Emblem without the prior consent of the FIM.

D. Counterfeiting

Any counterfeiting of the FIM Homologation Label or any FIM material subject to the FIM Intellectual Property Rights arising out in relation with the Homologation Notice constitutes a contractual breach and entitles FIM to claim for damages.

The FIM and the Applicant agree that a close collaboration and an active approach are required to act against counterfeit versions of the FIM Homologation Label.

If the Applicant or the FIM becomes aware that a third party has produced or sold counterfeit versions of the FIM Homologation Label, it shall inform the other party without delay.

If the Applicant becomes aware of counterfeit versions of the FIM Homologation Label, the Applicant may take any measures it sees fit, including without limitation by issuing a warning through different communication channels. The Applicant undertakes to make reasonable endeavours to act at its own cost against counterfeits of the FIM Homologation Labels including without limitation by taking any

practical measures to minimise or eliminate the manufacture, sale, distribution, advertising and/or use of counterfeit versions of the FIM Homologation Label. The Applicant shall inform the FIM of any measures and/or actions it takes accordingly.

If the Applicant has clear and unambiguous evidence that a party has produced or sold counterfeit versions of the FIM Homologation Label, and if the Applicant decides to instate proceedings against that party, it shall inform the FIM at its earliest convenience and provide the FIM with a reasonable time delay for the FIM to consider joining the proceedings as a party.

E. Model Stability

With respect to each Product submitted for homologation, the Applicant undertakes not to modify the following (the list is not exhaustive): for the purposes of the FRHP Application:

- i. the trademark(s)
- ii. the commercial name(s)
- iii. the design
- iv. the materials
- v. the manufacturing process
- vi. dimensions
- vii. components

In addition to the foregoing and without limitation thereof, the Applicant undertakes not to make any changes that generally alter the FIM racing homologated Product Model substantially without the prior written approval of the FIM.

Failure to respect the aforementioned undertakings may lead to immediate withdrawal of the homologation.

If the Applicant wishes to update an existing homologation in order to take into account one or more of the aforementioned items (the list is not exhaustive) it shall send the present Homologation Manual, duly completed and signed, with the requested information and the related documents attached thereto.

Based on this application, the FIM will assess whether the request falls within the scope of an update of an existing homologation or whether a new homologation is required.

F. Testing

The Testing Laboratory will be the sole entity approved to perform the tests in accordance with the present Homologation Manual.

All the homologation tests will be carried out, regardless of whether or not the samples comply with the requirements.

Subject to the availability of the Testing Laboratory and by appointment with the Testing Laboratory, one representative of each Applicant may attend the homologation tests carried out by the Testing Laboratory for its own samples and in absence of other Applicants.

The Testing Laboratory shall issue a Test Report (dated and signed) on the results of the tests performed and send it exclusively to the FIM. Such Test Report shall be sent to the FIM within a period of 2 (two) months after the date of receipt of the Samples. No Test report will be assessed by the FIM if the Application of the Applicant is not complete by this time.

G. Granting of the Homologation

The FIM will check and study the Test Report issued by the Testing Laboratory and is the sole authority having the power to assess it. When the FIM is satisfied that the homologation can be granted, the FIM will inform the Applicant and send a signed Homologation Notice, to be returned to the FIM countersigned by the Applicant. In principle, this Homologation Manual will be sent by the FIM within a month after the date of receipt of Test Report from the Testing Laboratory. The Homologation Notice will notably contain the conditions of use of the Homologation Emblem available for both the Applicant and the FIM. In the case a homologation is updated, an amendment to the existing Homologation Notice will be issued.

The homologation comes into effect only after the FIM has received the Homologation Notice countersigned by the Applicant and once it is signed by the FIM. The Applicant will then be entitled to refer to the homologated Product as "FIM racing homologated" and will be entitled to use the Homologation Emblem in accordance with the FIM's instructions.

In the event that the Product Model does not meet the acceptance criteria and is therefore not granted the FIM Racing Homologation, the Applicant will be informed accordingly through a formal Homologation Refusal.

The FIM may transmit the Test Report to the Applicant upon request.

H. No Assignment

The FIM Racing Homologation shall be binding on and ensure to the benefit of the parties and their respective successors and permitted assigns. The Applicant shall not be entitled to assign or sub-contract its rights or obligations under the Homologation Notice in whole or in part without the prior written consent of the FIM.

I. Labelling

If the homologation is granted, the Applicant will order a certain quantity of Homologation Labels. The only human-eye visible information on the Homologation Label will be the FRHP logo. The rest

of the information will be uploaded on a QR code that is linked to the digital database and can be modified whenever necessary. The QR code carries a unique identification number, which, when scanned, will show the Company name, the Product Model and any other relevant information related to the Product.

The use of Homologation Labels to the Applicant is subject to the prior signature of the Homologation Notice by the Applicant and the FIM.

The Homologation Label shall be firmly be sewn on the chinstrap at an accessible location for easy scanning the Product. The Homologation Labels shall not be available outside the Applicant's premises and shall only be fitted by the Applicant or their official agents on the respective homologated Products. For the avoidance of doubt, only Homologation Labels ordered from the FIM shall be used. Each unit of the respective FIM racing homologated Product model which will be manufactured and used/intended for racing must carry the official Homologation Label.

The Applicant undertakes and warrants that it applies the Homologation Label only to Products consistent with the actual Samples submitted to obtain the homologation.

The Homologation Label will be scanned by the FIM, which reserves the right for its officials or the officials of an FMN to remove it, or to remove the Product Model from the digital database, where there are valid reasons to do so.

J. Post-Homologation Controls

The FIM reserves the right to carry out post-homologation control tests on Products selected at random at the production site, at events or via a distribution channel, at any time. It also reserves the right to withdraw the homologation forthwith should the Products subject to random post-homologation controls be found not to be in conformity with the FIM criteria. The Applicant will be notified of the possible non-conformity of the Product.

K. Invoicing

A Homologation Label cost will be applied by the FIM to ensure the viability of the FRHPhe by covering notably the related operational, maintenance and development costs. A net amount of CHF 4.50 (Four Swiss francs and fifty cents) per label shall be paid by the Applicant.

Payment of the fees and the Homologation Label costs shall be made in full without any set-off, deduction or other withholding whatsoever. For the avoidance of doubt, any possible tax (withholding tax e.g.), duties or charges due on the payment of such fee and Homologation Labels costs shall exclusively be borne by the Applicant. All sums provided for in this Homologation Manual are exclusive of VAT which shall be paid (if applicable) by the Applicant in addition thereto.

In cases where the homologation is granted, the invoice in respect of the Homologation Label cost will be issued together with the Homologation Notice; these shall be respectively paid and signed in due time by the Applicant. The payment of the invoice shall be effected within 30 (thirty) days after

receipt and is a condition for valid homologation, without which the homologation can be withdrawn forthwith.

In cases where the homologation is not granted, the only the Homologation Refusal will be issued.

In addition and in any case, the Applicant agrees and acknowledges that a fee will be applied by the Testing Laboratory and charged to the Applicant to cover notably the costs related to the tests requested by the Applicant for each homologation application. The quote related to this fee will be sent to the Applicant by the Testing Laboratory once the Application Form has been validated by the FIM.

Concerning post-homologation controls, if the Product is deemed non-compliant with FIM Product Standard, the FIM will invoice the Applicant the fixed amount of CHF 5'000.- (five thousand Swiss francs). That amount corresponding to the maintenance costs includes notably the costs (if any) of purchasing the Products, the costs of the tests and the administrative costs.

If it is established that if the Product complies with the FIM Product Standard, no costs will be charged to the Applicant.

L. Warranties Regarding Environmental Responsibility and Compliance With Labour, Health And Safety Regulations

The Applicant hereby warrants, represents and undertakes that it has all necessary rights (including but not limited to any intellectual rights), permissions, power and capacity to enter into this Homologation Manual and to perform the obligations deriving from it and, in so doing, is not in breach of any obligations nor duties owed to any third parties and will not be so as a result of performing its obligations under this Homologation Manual.

The Applicant hereby warrants that the manufacture and assembly of the Product takes place in strict compliance with the applicable legislation and regulations applicable to labour, health and safety (including but not limited to Article 32 of the UN Convention on the Rights of the Child) in the country(ies) in which the Product(s) is/are manufactured or assembled and in the countries in which it conducts business.

The Applicant hereby warrants that it observes the environmental obligations and the provisions of environmental legislation and regulations applicable in the country in which Products are manufactured or assembled and in all countries where it conducts business.

The Applicant hereby certifies that it uses its best efforts to limit emissions and use safe, energy-saving and environmentally friendly technologies in the manufacture and assembly of the Product(s) for which the Application is being made.

M. Indemnities and Liability

The Applicant acknowledges that it is and remains the sole entity that can be held liable, in contract tort or under statute, in case of any loss or damage suffered by users and third parties, imputed, directly or indirectly, to the homologated Product.

As the FIM is not involved in any way whatsoever with the manufacturing of the Product, the FIM shall not in any case be liable for any direct or indirect or consequential loss or damages (whether for loss of profit, loss of business, depletion of goodwill or otherwise and including but not limited to any damage to property or death or injury) caused to the Applicant or third parties arising from any possible defect(s) related to the Product. In this regard, the Applicant hereby agrees to indemnify, release and hold harmless the FIM, its employees, agents, officials, representatives and volunteers from and against any and all possible product liability claims with regard to the Product.

The Applicant agrees to defend, hold harmless and indemnify the FIM against all loss, damages, costs and payments, including reasonable legal expenses, arising out of any third party claims (including but not limited to any intellectual property infringements claims) or allegations related to any breach by the Applicant of its warranties or obligations under this Homologation Manual.

All the warranties and indemnities made under this Homologation Manual shall remain in force indefinitely.

The FIM shall not in any case be liable in contract, tort or otherwise (including any liability for any negligent act or omission) for any direct or indirect or consequential loss or damages caused to the Applicant or third parties arising from breach or out of or in connection with the FRHPhe. In any event, the FIM's maximum aggregate liability in contract, tort, or otherwise (including any liability for any negligent act or omission) howsoever arising out of or in connection with FIM's obligations under the FRHPhe (e.g. to process the submitted Application Form, open the homologation procedure, assess the Test Report, issue the Homologation Notice or Homologation Refusal within a month of receipt of the Test Report, ship labels on Applicant's request, send Test Report on Applicant's request) in respect of any one or more incidents or occurrences in the framework of the FIM Racing Homologation shall be limited to a sum equal to the amount of CHF 5'000.- (five thousand Swiss francs). Such exclusion or limitation of liability shall also apply to the personal liability of employees, agents, representatives, officials and volunteers of the FIM.

For the avoidance of doubt, nothing in this Homologation Notice shall limit the liability of the Applicant towards the end-users or to other third parties or shall cap the Applicant's liability to the FIM.

N. Confidentiality

The FIM and the Applicant undertake to keep the terms of the Homologation Manual and Notice strictly confidential.

The FIM undertakes to treat and keep confidential any details provided by the Applicant and not to divulge any information as to testing of the Product Samples, materials used by, or manufacturing processes employed by the Applicant, or any designs, drawings, specifications, or other technical or confidential information as to the Applicant's products or prototypes of products, to anyone without prior written permission of Applicant.

It is understood that the FIM may publish general data derived from testing without disclosing any tradename or Applicant/Supplier identifications.

The FIM's obligation of confidentiality shall be limited in so far as local laws and/or safety considerations and/or instances of counterfeiting may require certain information to be divulged.

The Applicant hereby waives all requirements of confidentiality with respect to its Suppliers and Distributors vis-à-vis the FIM.

Except for promotional purposes as provided for in this Notice, no public announcement shall be made by the Applicant in relation to the FRHPhe without the prior written consent of the FIM.

O. Insurance

The Applicant hereby certifies that it is properly insured against all risks which may arise from or in connection with the Product and that it will at all times maintain an appropriate product liability insurance policy in respect thereof. The Applicant hereby agrees to provide a copy of the policy contracted upon simple request of the FIM.

The Applicant shall maintain at its own expense general and professional liability insurance and public liability insurance for adequate amounts for any one occurrence or series of occurrences arising out of any one event. Such insurance policies shall include cover in respect of product liability insurance for third party claims, and for the indemnification of the Applicant's obligations under the Homologation Manual and Notice.

The Applicant undertakes and warrants that it shall not do anything or omit to do anything that may affect the validity and/or compromise the applicability of any insurance coverage referred to in this Homologation Manual.

P. Withdrawal

Without this giving rise to any indemnity whatsoever, any decision will not give rise under any circumstances to any claim against the FIM from the Applicant. The FIM may immediately and without notice (in addition to and not in substitution for any of its other rights and remedies under this Homologation Manual or in law) withdraw the FIM Racing Homologation granted to the Applicant in the following cases:

- i. where the Product submitted for homologation no longer meets the (new and/or amended) standards required for entry and/or the acceptance criteria as defined by the FIM (see inter

alia Section VI **CONTRACTUAL TERMS AND CONDITIONS, J. Post-Homologation Controls** above);

- ii. where any conduct (e.g. act or omission, behaviour, public statement, etc.) whatsoever on the part of the Applicant, his management, employees, representatives or agents, which causes or may cause any prejudice (e.g. any direct or indirect or consequential loss or damages (whether for loss of profit, loss of business, depletion of goodwill or otherwise and including but not limited to any damage to property or death or injury)) to the FIM or its reputation;
- iii. in the event that the Applicant commits a breach of any of its obligations under this Homologation Manual.

Q. Consequences of Withdrawal

Upon withdrawal of the FIM Racing Homologation:

- i. all of the rights granted by the FIM in the framework of the FRHPhe (including those granted under this Homologation Manual) shall forthwith terminate and, where applicable, automatically revert to the FIM;
- ii. the Applicant shall not use or exploit its previous connection with the FRHPhe, whether directly or indirectly;
- iii. all sums due and payable to the FIM by the Applicant at the date of withdrawal of the FIM Racing Homologation shall be paid immediately together with any accrued interest on the same;
- iv. in the event that the withdrawal of the FIM Racing Homologation arises from non-payment by the Applicant of any sum due under this Homologation Manual, the FIM shall, without prejudice to any other rights under this Homologation Manual or law, be entitled to receive the balance then outstanding of the total Homologation Fee and Homologation Labels costs as set out in Section VI **CONTRACTUAL TERMS AND CONDITIONS, K. Invoicing** of this Homologation Manual;
- v. the Applicant shall not have any right to any indemnity or payment of compensation or damages;
- vi. the FIM may make a public announcement regarding the withdrawal of the FIM Racing Homologation.

If the FIM Racing Homologation is withdrawn by the FIM pursuant to Section VI. **CONTRACTUAL TERMS AND CONDITIONS, P Withdrawal** above, the Applicant shall be required to pay the FIM a penalty in the amount of CHF 5'000.- (five thousand Swiss francs). The penalty is payable even if the FIM has not suffered any loss or damage.

Furthermore and in any case of withdrawal of the FIM Racing Homologation, the FIM is entitled to recover from the Applicant any losses and damages as may be allowed under the law.

To apply for re-homologation for a withdrawn Product Model, the Applicant should follow the normal application process. The application will be treated as a new submission.

R. Waiver

Failure or neglect by either party to enforce at any time of the provisions hereof shall not be construed nor shall be deemed to be waiver of either party's rights hereunder nor in any way affect the validity of the whole or any part of this Homologation Notice nor prejudice either party's rights to take subsequent action.

S. Announcement

No announcement shall be made by the Applicant in relation to the FRHPhe without the prior written consent of the FIM.

T. Transparency

The Applicant has a duty of transparency and disclosure towards the FIM as the homologating body.

Any sporadic or regular malfunction or sporadic or systemic defect affecting the Product that arises at any time shall immediately be reported to the FIM and remedial measures proposed. Where necessary, the homologation will be withdrawn.

U. Severability

If any provision of this Homologation Notice shall be held to be invalid, illegal or unenforceable, then both parties shall be relieved of all rights and obligations arising under such provision and such provision shall be modified to the extent necessary to make it valid, legal and enforceable whilst preserving the intent of the parties. All other provisions of this Homologation Notice shall be regarded as fully valid and enforceable unless otherwise proved.

V. Termination

The Applicant may withdraw its Application and terminate the FIM Homologation Manual and Notice upon written notice to the FIM before the granting of the FIM Racing Homologation or upon at least thirty (30) days' notice once the Homologation is granted.

Either party (the Applicant or the FIM) may terminate this Homologation Notice with immediate effect upon written notice to the other party if at least one of the following conditions is met:

- i. if the other party is dissolved (other than pursuant to a consolidation, amalgamation or merger);
- ii. If the other party becomes insolvent or is unable to pay its debts or fails or admits in writing its inability generally to pay its debts as they become due;

- iii. if the other party seeks or becomes subject to the appointment of an administrator, provisional liquidator, conservator, receiver, trustee, custodian or other similar official for it or for all or substantially all its assets;
- iv. if the other party has a secured party take possession of all or substantially all its assets or has a distress, execution, attachment, sequestration or other legal process levied, enforced or sued on or against all or substantially all its assets and such secured party maintains possession, or any such process is not dismissed, discharged, stayed or restrained, in each case within thirty (30) days thereafter; or
- v. if the other party causes or is subject to any event which, under the applicable laws of any jurisdiction, has an analogous effect to any of the events specified in clauses *i* to *iv* inclusive above (of this **Section VI CONTRACTUAL TERMS AND CONDITIONS., V**).

W. Termination Consequences

Upon termination of the FIM Homologation Manual and Notice:

- i. all of the rights granted by the FIM in the framework of the FRHPhe (including those granted under the Homologation Manual and Notice) shall forthwith terminate and, where applicable, automatically revert to the FIM;
- ii. the Applicant shall not use or exploit its previous connection with the FRHPhe, whether directly or indirectly;
- iii. all sums due and payable to the FIM by the Applicant at the date of termination of the FIM Racing Homologation shall be paid immediately together with any accrued interest on the same;
- iv. in the event that the termination of the FIM Racing Homologation arises from non-payment by the Applicant of the FIM Racing Homologation fees and payable amounts, the FIM shall, without prejudice to any other rights under this Homologation Notice and Manual or law, be entitled to receive the balance then outstanding of the total Homologation fee and the Homologation Label;
- v. the Applicant shall not have any right to any indemnity or payment of compensation or damages.
- vi. the Applicant shall immediately surrender to the FIM all the unused FIM Homologation Labels and any other materials or documents issued to it pursuant to this Notice.
- vii. the FIM may make a public announcement regarding the termination of the FIM Homologation

The termination of the Homologation Notice and Manual will not under any circumstances give rise to any liability on the part of FIM to pay any compensation to the Applicant, including but not limited to, for loss of profits or goodwill.

X. Notices

Any notice given under the Application shall be in writing and signed by authorised representatives on behalf of the party giving it and shall be sent by hand, prepaid recorded or special delivery post, courier, fax and/or email, marked for the attention of the relevant party and to the address and/or number set out below:

In the case of the Applicant:

To the Address, email and telephone indicated in the Application.

In the case of the FIM:

Attention of: FIM Racing Homologation Programme responsible

Route de Suisse 11

CH-1295 Mies

Suisse

Email: frhp@fim.ch

Fax N°: +41 22 950 95 00

Y. Applicable Law and Arbitration

Any dispute arising from or in connection with the FRHP (including the validity or interpretation of this Homologation Manual) shall be governed by and interpreted exclusively in accordance with Swiss law and shall be submitted exclusively to the Court of Arbitration for Sport (CAS) and resolved definitively in accordance with the Code of Sports-related Arbitration in force on the date on which the Request for Arbitration is submitted.

The Panel shall consist of one arbitrator, which shall be independent of the Parties and appointed in accordance with the Code of Sports-related arbitration of the CAS. The seat of the arbitration shall be Lausanne (Switzerland). The arbitral proceedings shall be conducted in English.

The Expedited Procedure shall apply to the arbitration proceedings including to the provisional and super-provisional measures. The time-limit with respect to the designation of an arbitrator shall be 15 (fifteen) days. If the circumstances so justify, the Panel may extend or shorten the above time-limit.

Notwithstanding the above, the parties may agree at any time to submit the dispute to mediation in accordance with the CAS Mediation Rules.

Furthermore, the Applicant may not seek damages or take action to gain compensation for any inconvenience or other loss incurred. Finally, any decision to withdraw the FIM Racing Homologation will have immediate effect and the stay of its execution will not be entertained in any circumstances by the CAS Panel and cannot therefore be submitted to arbitration.

The Applicant confirms that he has read and agreed to the present Homologation Manual. In particular, the undersigned Applicant confirms that he is cognisant with and accepts the Term and Conditions contained in this Homologation Manual.

Applicant's representative

Name Signature

On ____/____/____

Note: Please initial each page in the dedicated boxes